

RELCO®'s **Star Valve** is a rotary valve designed specifically for the pneumatic transport and differential pressure air lock applications for cheese curd and similar dairy products. Available in two sizes, it is designed to dairy equipment standards featuring easy removable vanes and a variety of production and cleaning configurations.

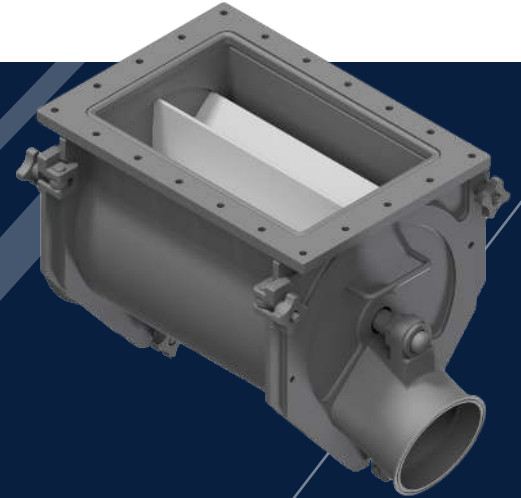

FEATURES

- 10" up to 14,000 pounds per hour
- 12" up to 24,000 pounds per hour
- Bottom discharge and blow thru options
- Quick release endcaps for easy cleaning and maintenance
- O-rings for sanitary sealing of end caps and the valve mating
- FDA PTFE lip seal for reliable shaft sealing
- Direct drive
- Removable vanes for easy cleaning
- Sanitary swivels (4" only)
- Material is 316 Stainless

