

The RELCO® Bag Break Station is ideal for feeding powder into pneumatic conveying systems. Constructed from stainless steel and internal polished welds, the bag break station meets sanitary USDA dairy standards and is designed with oversized rear plenum to contain dust within the hopper.

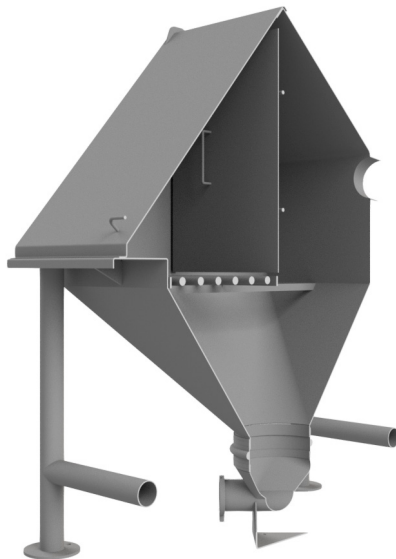
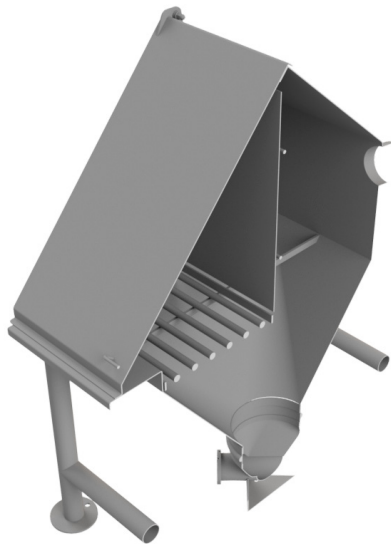

FEATURES AND BENEFITS

- Designed for USDA Dairy Application
- Heavy-duty stainless steel construction that is durable and corrosion resistant
- Gas strut-assisted plenum cover assists the operator when opening the plenum cover and holds the plenum cover open while the bag break station is in use
- Bag preparation space incorporated at the grate area where an operator prepares the bag for tipping
- Bag grate can easily be removed from the plenum without the use of tools
- Deep, recessed bag grate ensures the products falls into the hopper during the tipping process
- Large tipping area (40 inch x 20 inch deep bag grate) allows the operator space to tip product
- Oversized rear plenum contains nuisance dust
- When connected to a Dust Collector, dust is evacuated through the provided dust pick up location, assisting in keeping the work area clean
- Custom designed applications available to meet individual process requirements